

RECOMMENDED FPC/FFC DIMENSIONS
GENERAL TOLERANCE ±0.05

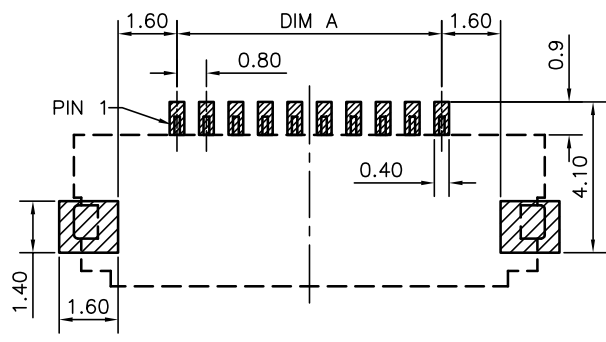

RECOMMENDED PCB LAYOUT
GENERAL TOLERANCE ±0.05

- NOTES:
- MATERIAL:
 - HOUSING: THERMOPLASTIC, HIGH TEMP; SOMIKASUPER LCP E6808U HFZ-NA ,UL94V-0.
 - ACTUATOR: THERMOPLASTIC, HIGH TEMP; MITSUI CHEMICALS ARLEN PA6T RA230NK, UL94V-0.
 - CONTACT: COPPER ALLOY
 - FITTING NAIL: COPPER ALLOY
 - FINISH:
 - CONTACT:
 - 50u" MIN NICKEL UNDER PLATING OVERALL.
 - 1: GOLD FLASH ON CONTACT AND SOLDER AREA.
 - B: 5u" GOLD ON CONTACT AREA AND GOLD FLASH ON SOLDER AREA.
 - W: 1u" GOLD ON CONTACT AREA AND SOLDER AREA.
 - A: 3u" GOLD ON CONTACT AREA AND GOLD FLASH ON SOLDER AREA.
 - FITTING NAIL:
 - 50u" MIN NICKEL UNDER PLATING OVERALL.
 - 100u" MIN. MATT TIN PLATING ON SOLDER TAILS(LEAD FREE).
 - REFLOW SOLDER CAPABLE TO 260°C PER ACES SPEC.
 - SPEC. PLS. REFER TO PS-51551-xxxx-xxx
 - PACKAGE PLS. REFER TO 51551-xxxx-xx-TRP
 - ACCORDING TO J-STD-020d.1, THIS SERIES PRODUCTS ARE LISTED IN LEVEL 3
 - PART NUMBER

51551-XXX X X-XXX

NO OF CKT

PACKING
0: TAPE & REEL
4: TAPE & REEL WITH MYLAR

	HOUSING MATERIAL&COLOR	ACTUATOR MATERIAL&COLOR	HALOGEN FREE
001	HALOGEN FREE PLASTIC & NATURAL	HALOGEN FREE PLASTIC & BLACK	HF
002	HALOGEN FREE PLASTIC & NATURAL	HALOGEN FREE PLASTIC & BLACK	HF

PLATING
1: GOLD FLASH
B: 5u" GOLD ON CONTACT
W: 1u" GOLD ON CONTACT
A: 3u" GOLD ON CONTACT

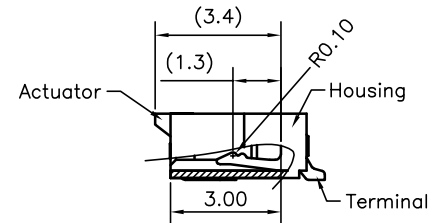
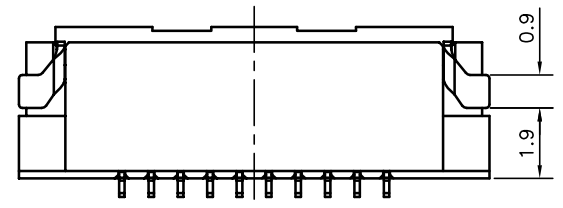
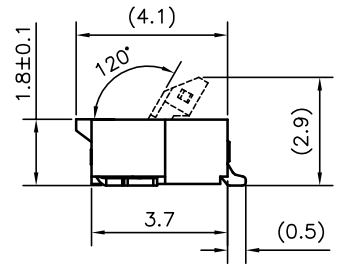
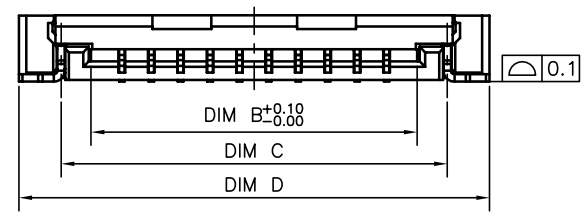
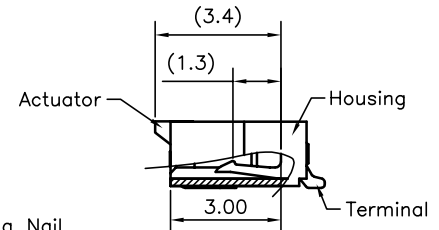
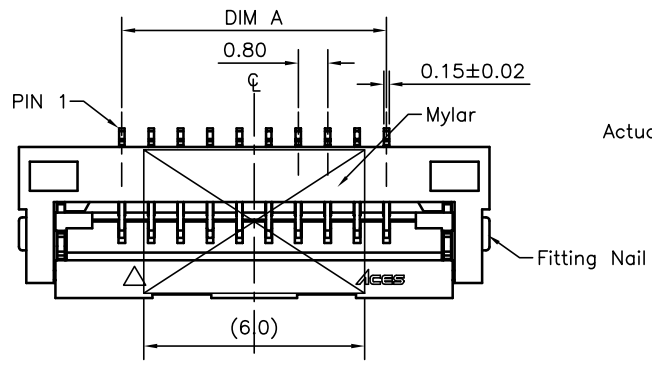

FOR 51551-xxxx-002

CKT	DIM A	DIM B	DIM C	DIM D
34	26.4	28.07	29.7	32.0
36	28.0	29.67	31.3	33.6
40	31.2	32.87	34.5	36.8

QUALITY SYMBOLS MAJOR Ⓢ CRITICAL Ⓢ	DRAWN BY Zhu, Wei	DATE 22/11/24	
GENERAL TOLERANCES (UNLESS SPECIFIED) X ±0.5 .X ±0.25 .XX ±0.15 .XXX ±0.1 ANGLES ±2°	CHECKED BY Xu, ZhiYong	DATE 22/11/24	
	APPROVED BY Xu, ZhiYong	DATE 22/11/24	TITLE 0.8 PITCH EASY ON FPC/FFC Conn. H=1.8mm TYPE
	UNITS mm	SIZE A4	REQ NO. N/A
	SCALE 5 : 1	SHEET NO. 1 OF 1	REV E
			DWG NO. 51551-XXXX-XXX